

## PN10 Tied Flanged Flexible Connector

### Features

- Flanged PN10 BS4504
- EPDM/NBR Body Option
- Zinc Plated Carbon Steel Oval Flanges
- Nylon Cord Fabric with Steel Reinforcement

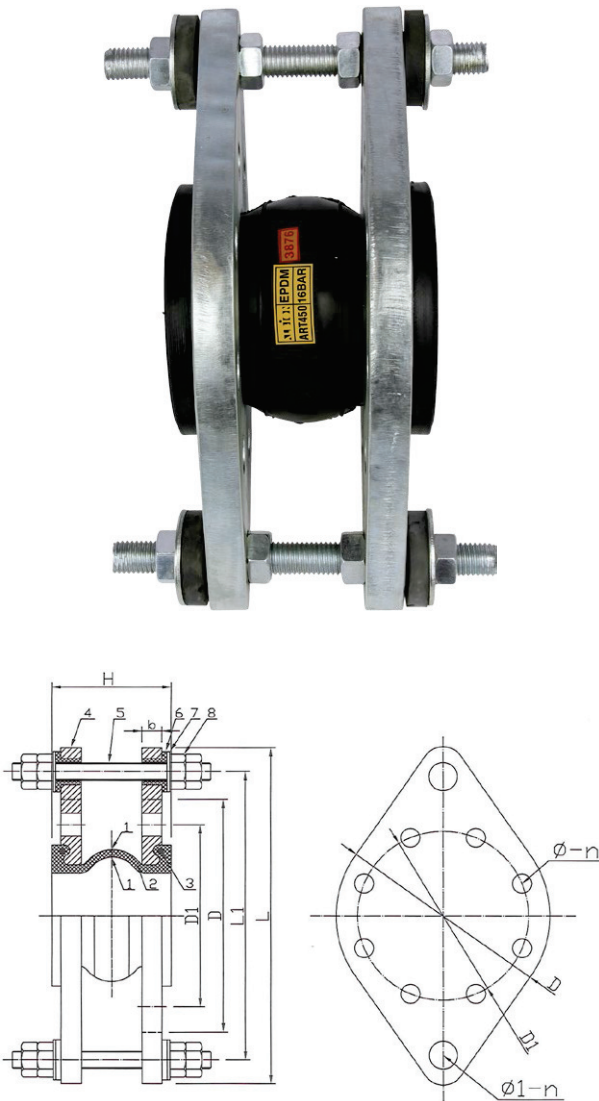

### Pressure / Temperature

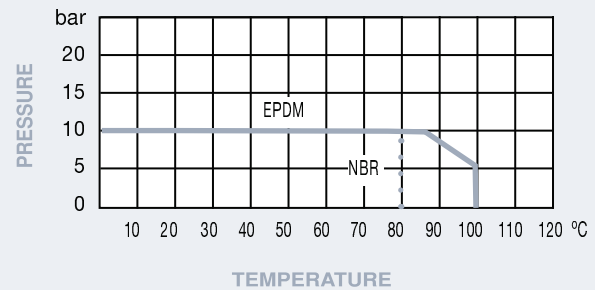

HD - Horizontal Displacement

DA - Deflection Angular

Ext - Extension

Comp - Compression

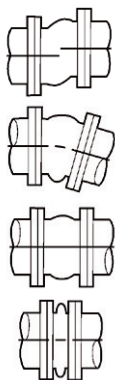

DN	32	40	50	65	80	100	125	150	200	250	300
L	250	260	275	295	310	330	360	395	450	535	590
L1	195	205	220	240	255	275	305	340	395	470	525
D	140	150	165	185	200	220	250	285	340	405	460
D1	100	110	125	145	160	180	210	240	295	355	410
H	130	130	130	130	130	130	130	130	130	130	130
b	14	14	16	16	18	18	20	20	22	22	26
Ø-n	18-4	18-4	18-4	18-4	18-8	18-8	18-8	22-8	22-8	22-12	22-12
Ø1-n	28-2	28-2	28-2	28-2	28-2	28-2	28-2	32-2	32-2	36-2	36-2
HD	12	12	12	12	12	12	12	12	12	12	12
DA	15°	15°	15°	15°	15°	15°	15°	15°	15°	15°	15°
Ext	8	8	8	8	8	8	8	8	8	8	8
Comp	15	15	15	15	15	15	15	15	15	15	15
Kgs	4.12	4.76	6.47	8.1	9.6	10.8	14.8	17.1	22.8	34.0	41.9

N.	Part Name	Materials 455	Materials 465
1	Body Inner & Outer	EPDM	NBR
	Body Core	Natural Rubber	Natural Rubber
2	Reinforcement	Nylon Cord Wire	Nylon Cord Wire
3	Pressure Ring	Steel Wire	Steel Wire
4	Flange	Carbon Steel	Carbon Steel
5	Limited Bolt	Carbon Steel	Carbon Steel
6	Rubber Washers	NR	NR
7	Plain Washers	Carbon Steel	Carbon Steel
8	Nut	Carbon Steel	Carbon Steel

### Technical Data

Max Pressure 10 Bar

Working Temperature -20°C to +100°C EPDM  
-20°C to +80°C NBR

Dimensions in mm

This data sheet is designed as a guide and should not be regarded as wholly accurate in every detail. We reserve the right to amend the specification of any product without notice.